

TREK

DOMANE

ISO SPEED

2020 DOMANE SLR/SL
SERVICE MANUAL



Table of Contents

1. Install common components	2
A. Install and adjust the seatpost	2
B. Install the front derailleur	3
C. Install the rear derailleur	3
D. Install the chain keeper	3
2. Route and install brakes	4
A. Install rear brake in frame	4
B. Install front brake and brake hose	4
3. Route cables and housings through the frame	5
A. Mechanical	5
Route front derailleur housing	5
Route rear derailleur housing	5
Install the down tube cable guide	6
Install the down tube window frame	6
B. Di2	7
Route the front derailleur cable	7
Route the rear derailleur cable	7
Route battery and install	8
Install the down tube window frame	9
Handlebar cable routing	9
4. Install the fork	11
5. Route and install the stem and handlebar	12
Install the stem	12
Install the handlebar	12
A. Mechanical	13
Connect the brake hose and housing/cables	13
Install the top tube cable guide	13
B. Di2	13
Install the top tube cable guide	13
Install the shift levers	13
6. Domane torque specifications	15
7. Service information	16
8. Appendix	17
A. Install the front isospeed	17
B. Install the rear IsoSpeed	20
C. Assemble and install the DT storage door	22
D. Install the T47 bottom bracket	24
E. Install fenders	25
Install front fender	25
Rear fender chart	26

1 INSTALL COMMON COMPONENTS

A. Install and adjust the seatpost

TOOLS AND MATERIALS REQUIRED

- Saddle
- Seatpost
- Seatpost wedge and bolts
- Lower seal
- Long stem 5mm hex
- Torque wrench

1. Remove any tape or rubber band from around the seatpost wedge prior to installation.

2. Install the lower seal into the bottom of the seatpost.

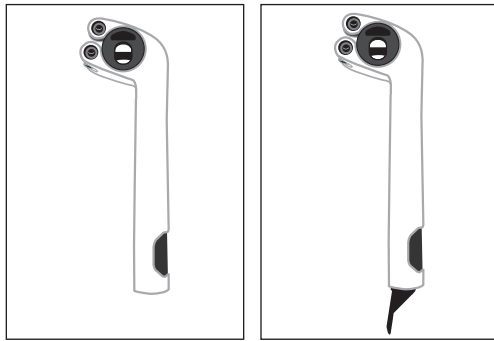

NOTE For full seatpost insertion, you may need to remove the lower seal.

3. Insert the seatpost into the seatmast. Be sure to have the wedge placed in the seatpost prior to insertion.

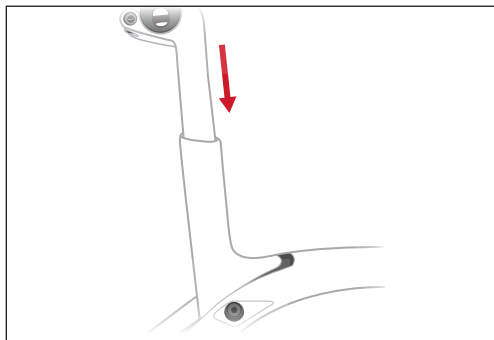

4. Tighten the bolt just until the seatpost and wedge are snug. Do not fully tighten yet.

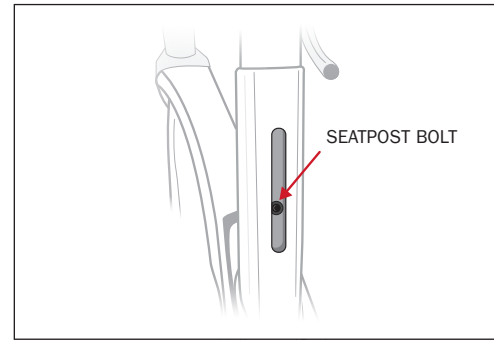

5. Install the saddle. Make sure the clamp ear correctly fits the saddle rail shape.

6. To adjust the angle of the top of the saddle, loosen the rear pinch bolt, adjust the angle, then re-tighten the bolt.

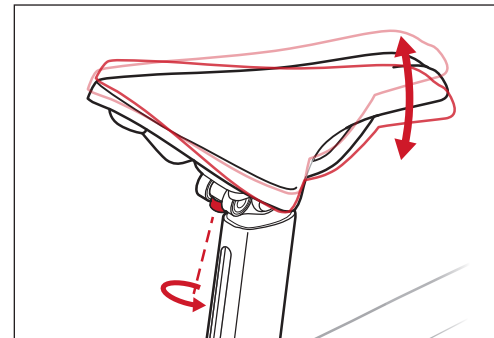

7. To adjust the fore/aft position of the saddle, loosen the side rail clamp bolt, slide the saddle, then re-tighten the bolt.

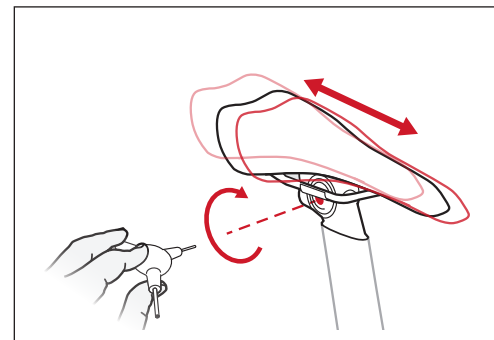

1 Install common components

8. To adjust the seat height, loosen the seatpost clamp bolt, adjust the height, and re-tighten the bolt to the recommended torque value.

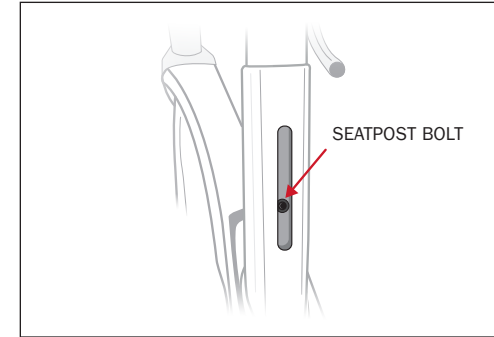

NOTE Use a long stem 5mm socket on your torque wrench to tighten the seatpost bolt. This will allow an improved fit on the bolt and will prevent wrench marks on the bike finish.

B. Install the front derailleur

1. Use the special carbon washer and bolt to install the front derailleur at the base of the front derailleur hanger. Tighten the bolt just until the derailleur is held. Do not fully tighten yet.

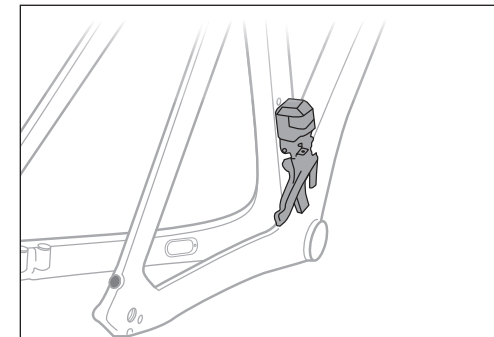

C. Install the rear derailleur

1. Install the rear derailleur on the rear derailleur hanger. Tighten to OEM torque spec.

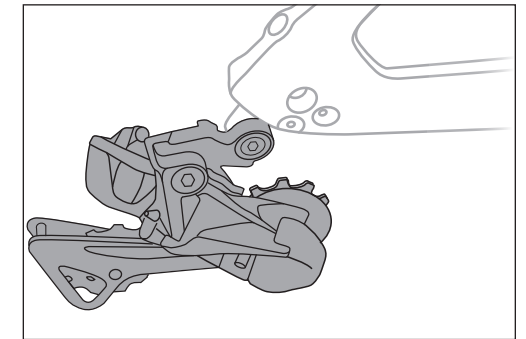

D. Install the chain keeper

1. Install the chain keeper at the base of the front derailleur hanger. Torque the bolt to 3Nm.

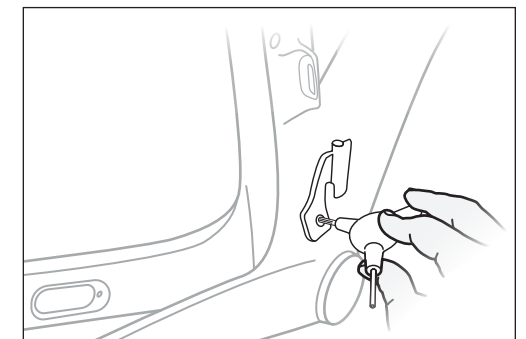

2 ROUTE AND INSTALL BRAKES

A. Install rear brake in frame

1. Please see the figure at the bottom of page 5 for the correct housing locations at the head tube.
2. Remove the rubber grommet from the non-drive side chainstay.
3. Slip the grommet onto the brake hose and route the hose through the grommet hole.

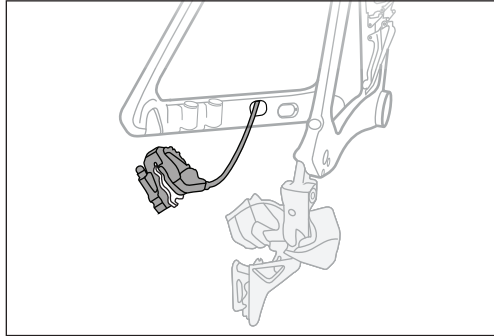

4. Route the hose through the bottom bracket, up the down tube, and out the head tube.

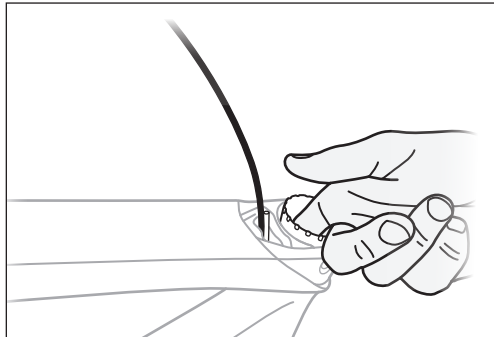

5. Fit the grommet back into the hole in the chainstay.
6. Bolt the brake in place.

B. Install front brake and brake hose

1. Place lower bearing on the fork race.
2. Route the hose through the fork access hole (non-drive side) and up through the hole at the back of the steerer tube.
3. Connect the brake to the fork. Tighten the bolt just until the brake is snug. Do not fully tighten.

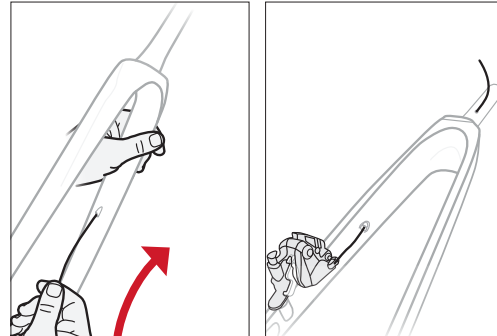

3 ROUTE CABLES AND HOUSINGS THROUGH THE FRAME

A. Mechanical

Route front derailleur housing

1. Route the front derailleur housing from the head tube, down through the down tube, and out the front derailleur hole at the base of seat tube.

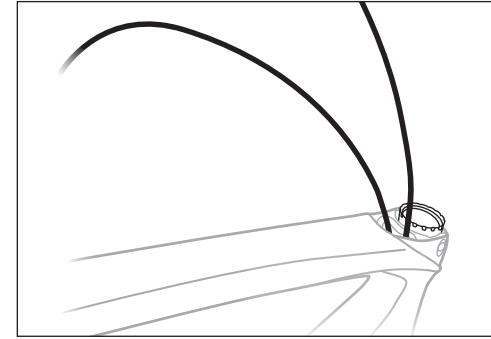

2. Insert the grommet onto the housing and place the housing in the stop on the front derailleur.

3. Set the grommet in place on the frame.

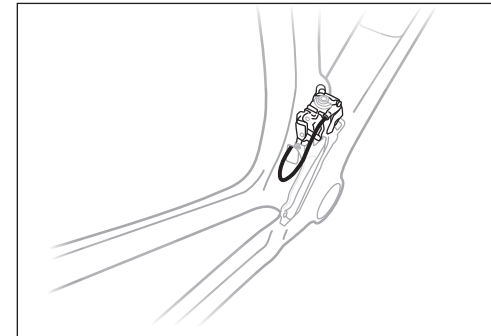

Route rear derailleur housing

1. Route the rear derailleur housing from the hole in the chainstay, through the bottom bracket, up the downtube, and out the top of the head tube.

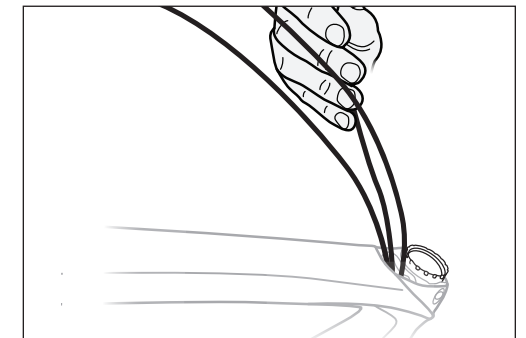
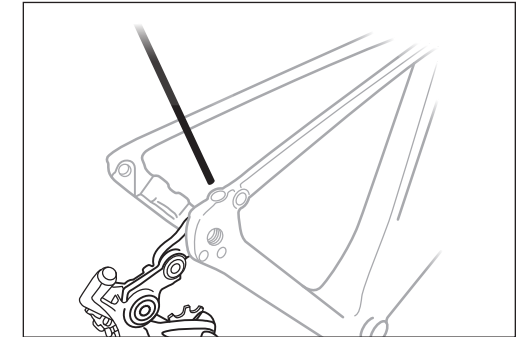

2. From the drive side of the head tube to the non-drive side, the location of the housing and hoses is:

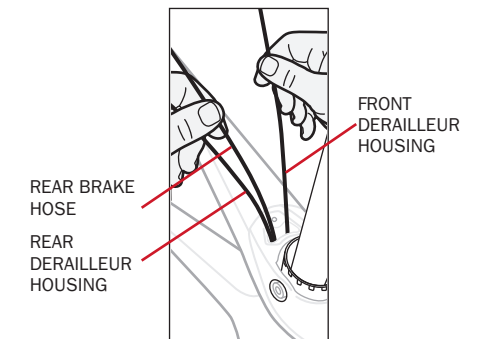

1. Front derailleur housing
2. Rear brake hose
3. Rear derailleur housing

3. Put the grommet around the derailleur housing and insert the grommet into the bottom of the drive side dropout.
4. Place the housing in the stop on the rear derailleur.

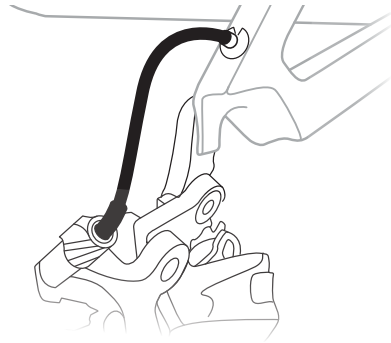

Install the down tube cable guide

1. Slide the cable guide into the down tube access hole and under the cables and hose.
2. Snap the cables and hose into the guide clips in the correct order and location (non-drive side to drive side):
 1. Rear brake
 2. Front derailleur
 3. Rear derailleur

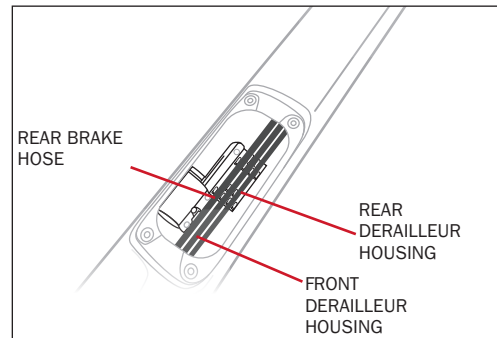

3. While holding the housing and hose at the head tube, move the guide down the downtube to line up the guide holes with the holes in the bottom of the downtube.

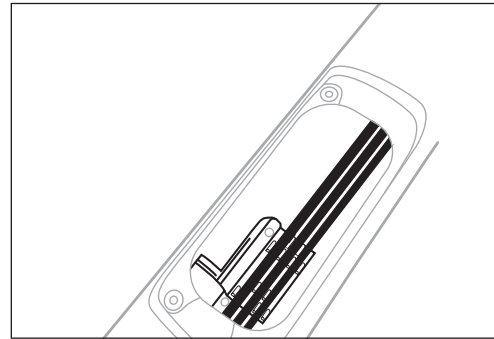

4. From the bottom of the down tube, use two bolts to connect the cable guide to the frame. Torque the bolts to 3Nm.

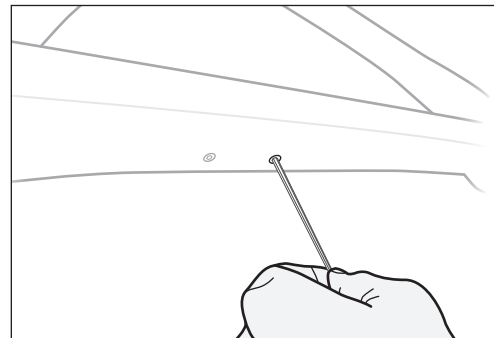

Install the down tube window frame

1. Install the window frame in the down tube storage hole.

NOTE Make sure the window frame tab is at the top of the storage hole.

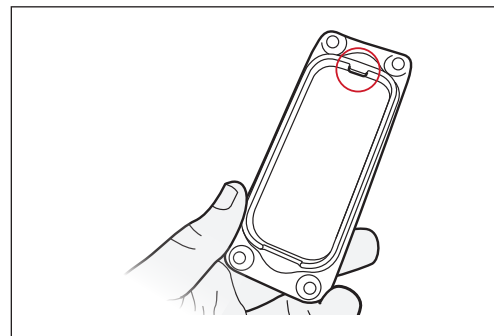

2. Tighten the bolts to 1.2Nm.

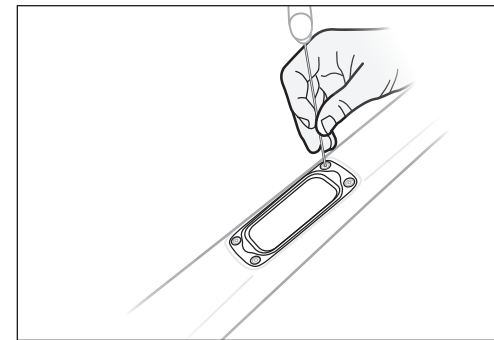

3. Install the storage cover with the lever pointing to the drive side.

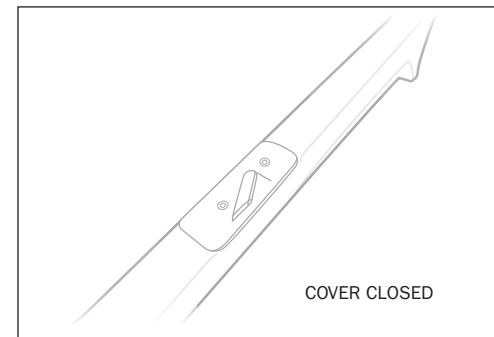
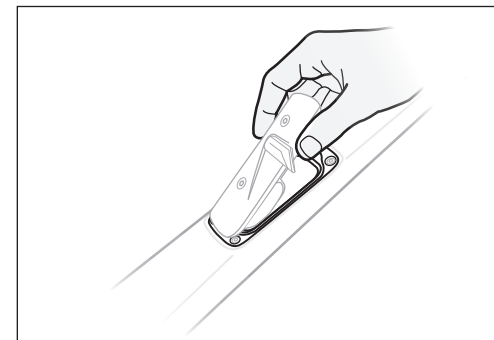

4. See the Appendix for the procedure: *Assemble and install the down tube storage door.*

B. Di2

Route the front derailleur cable

1. Connect the front derailleur cable to the front derailleur.
2. Place the cable through the grommet, into the hole at the bottom of the seat tube, and out the bottom bracket.
3. Set the grommet in place in the frame.

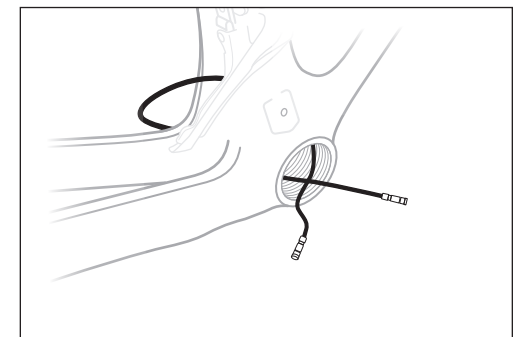
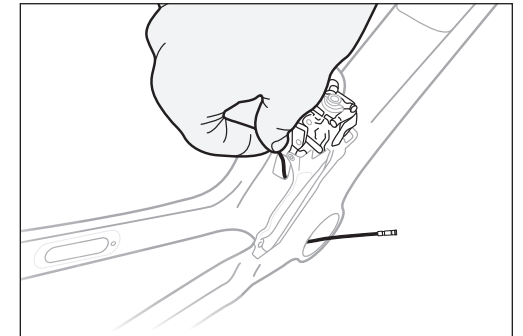

Route the rear derailleur cable

NOTE The rear brake should be installed and the hose routed up through the head tube.

Pro Builder Tip: To help with this installation, use the Park Tool IR-1.2 Internal Cable Routing Kit.

1. Connect the rear derailleur cable to the rear derailleur.

2. Route the rear derailleur cable from the hole in the driveside chainstay to the bottom bracket hole.

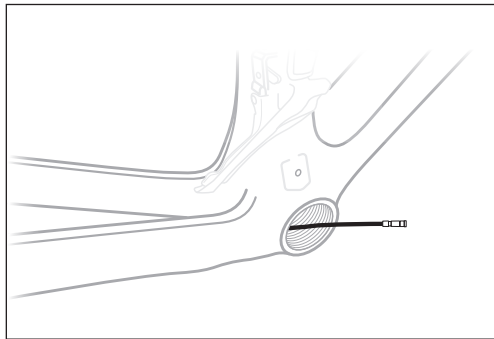
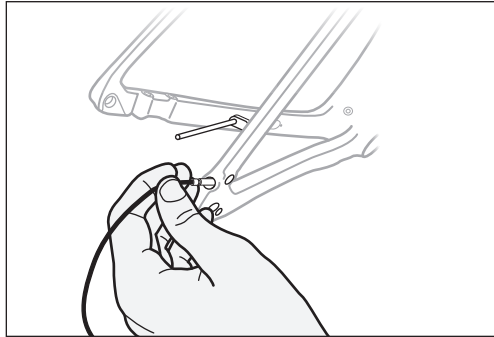

3. Put the grommet around the derailleur housing and insert the grommet into the bottom of the drive side dropout.

Route battery and install

1. Place the battery in the battery holder and cable guide.
2. Tighten the screws to 0.3Nm.

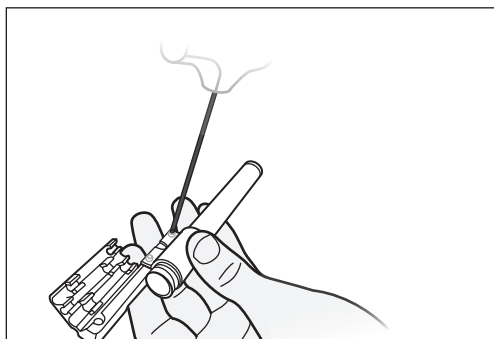

3. Connect the battery wire to the battery.

4. Route the battery wire in through the storage hole and out the bottom bracket hole.

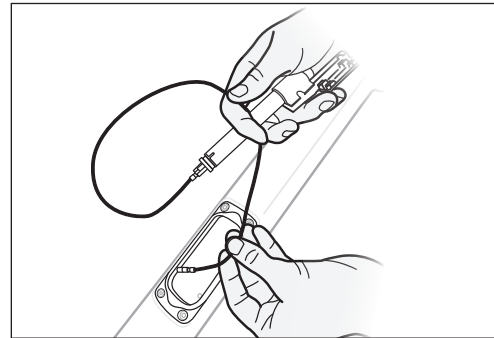

5. You should now have three wires out the bottom bracket hole.

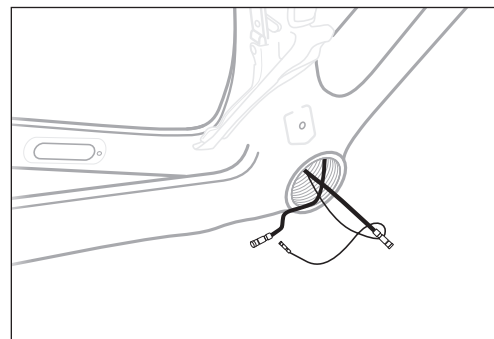

6. Slide the battery, wire, and the cable guide assembly in the storage hole and under the brake hose.

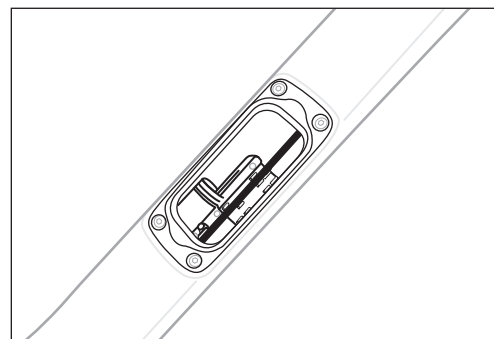

7. Snap the rear brake hose into the non-drive side slot in the cable guide.

8. At the top of the head tube, hold the rear brake hose and move the guide down the downtube to line up the guide holes with the holes in the bottom of the downtube.

9. From the bottom of the down tube, use two bolts to connect the cable guide to the frame. Tighten the bolts to 3Nm.

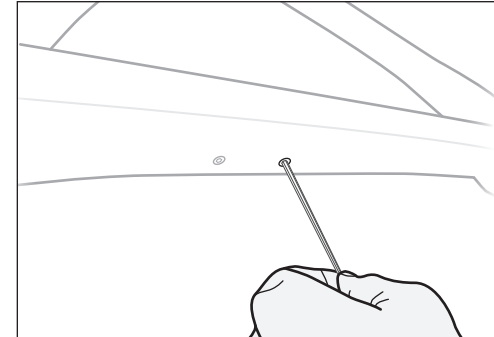

Install the down tube window frame

1. Install the window frame in the down tube storage hole.

NOTE Make sure the window frame tab is at the top of the storage hole.

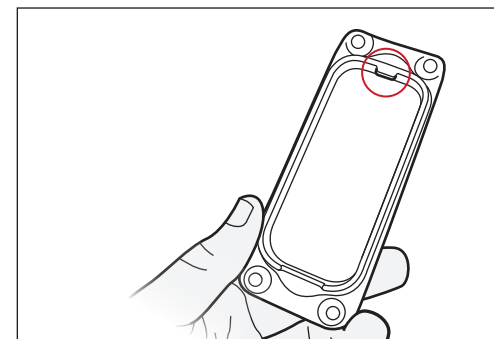

2. Tighten the bolts to 1.2Nm.

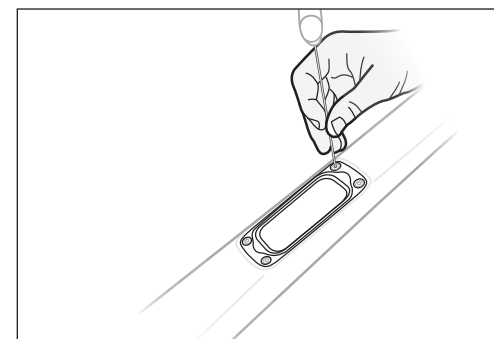

3. Install the storage cover with the lever pointing to the drive side.

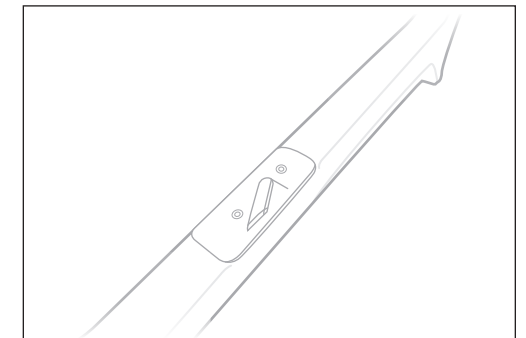
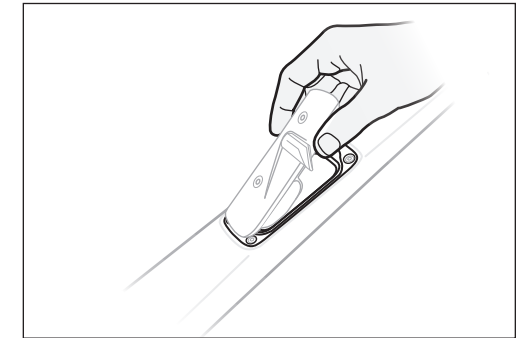

4. See the Appendix for the procedure: *Assemble & install the down tube storage door.*

Handlebar cable routing

Pro Builder Tips:

1. To help with this installation, use the Park Tool IR-1.2 Internal Cable Routing Kit.
2. For ease of cable routing, place the handlebar in a bike mount fixture.

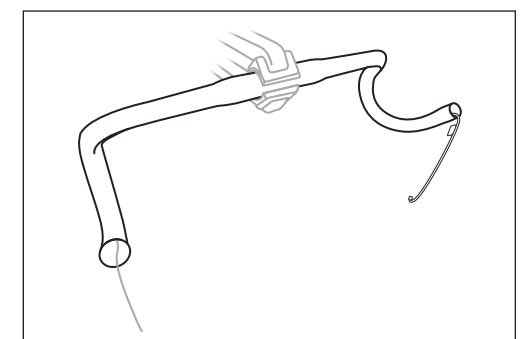

3 Route cables and housings through the frame

1. Route the Park Tool wire from the right bar end through the handlebar and out the left bar end.
2. Pull the long left shifter Di2 wire (1200mm) from the right bar end through the handlebar, and out the shifter hole in the bottom of the left side. Tape the wire to the handlebar.

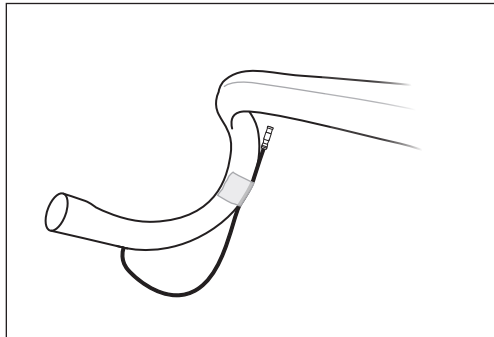

3. Route the short right shifter Di2 wire from the shifter hole in the bottom of the right side, and out the right side bar end. Tape the wire to the handlebar.

You now have two Di2 wires sticking out the right side handlebar end.

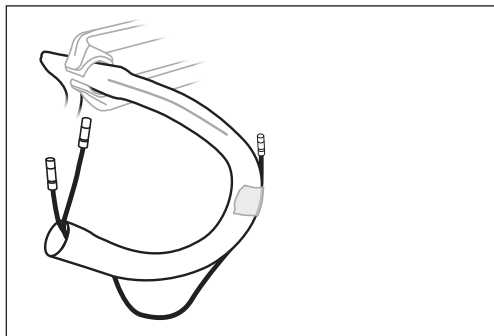

4. Plug the two wires into the bar end plug.

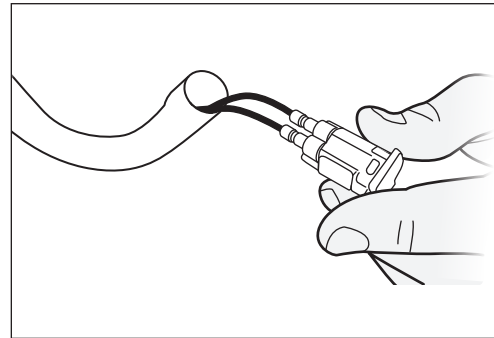

NOTE The location of the two wires in the bar end plug does not matter.

5. Route a Di2 wire from the top of the head tube, down the down tube, and out the bottom bracket hole. This wire connects to the right shifter.

You now have four Di2 wires sticking out the bottom bracket hole.

6. Plug all four wires into the junction box. The location of the wires does not matter.

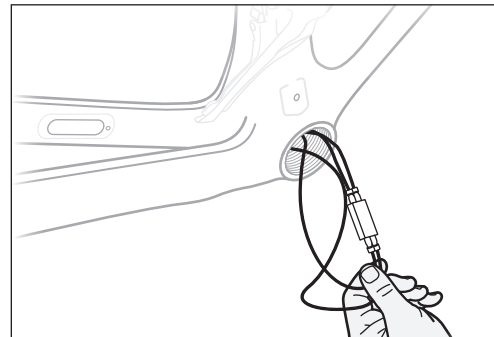

7. Put the junction box and four wires through the bottom bracket hole and into the down tube.

4 INSTALL THE FORK

Install the fork

1. With lower bearing installed on the fork, slide the steer tube and brake hose up through the bottom of the head tube.
2. Guide the brake hose out through the top tube cable hole.
3. Slide the steer tube through the IsoSpeed assembly.

NOTE Make sure the two brake hoses and the derailleur cable(s) are positioned in the top tube cable hole.

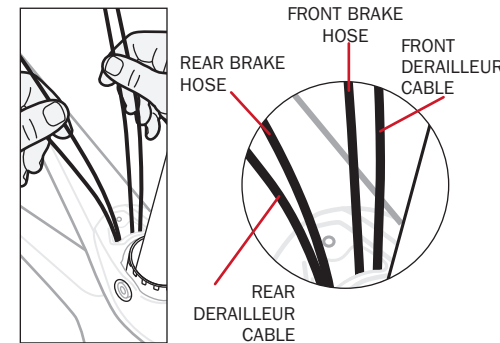

4. Install in order: Front IsoSpeed grommet, IsoSpeed spacer, upper bearing, split ring, and top cap.

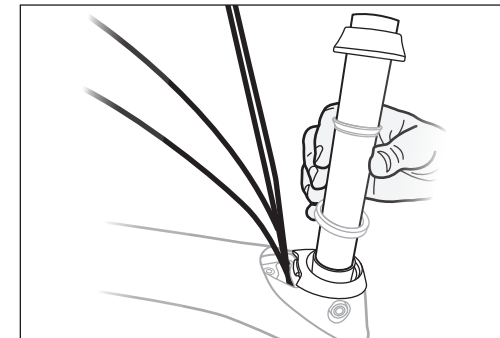

5. Install the brow cover. Flex the sides of the brow cover outward, and position it over the top of the head tube.

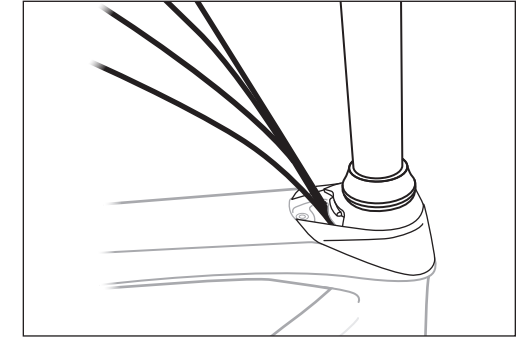

5 ROUTE AND INSTALL THE STEM AND HANDLEBAR

Install the stem

1. Install any desired headset spacers and the stem onto the steerer tube.
2. Align the stem and tighten the stem pinch bolts to the recommended torque.

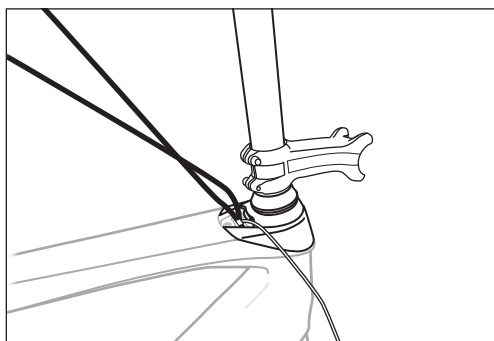

2. Put the handlebar in place on the stem and tighten the faceplate bolts to spec.

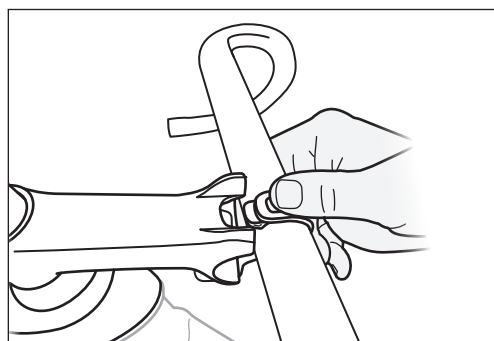

NOTE Make sure the tabs on the wrangler line up with the spaces on the stem.

3. When the cable wrangler, stem and handlebar are properly assembled, a person should be able to pull on the cable loop with no movement between the clip and the handlebar.

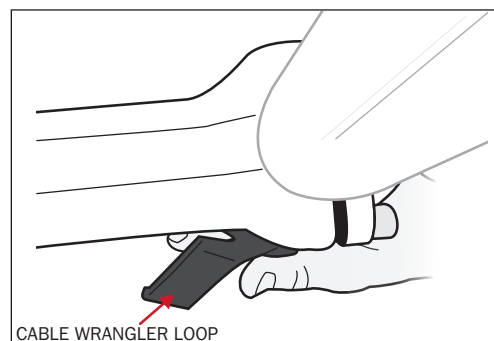

4. When properly assembled, you should not be able to see the cable wrangler tab at the bottom of the stem.



Install the handlebar

1. Snap the cable wrangler onto the handlebar. The location is important as the wrangler will sit in the stem.

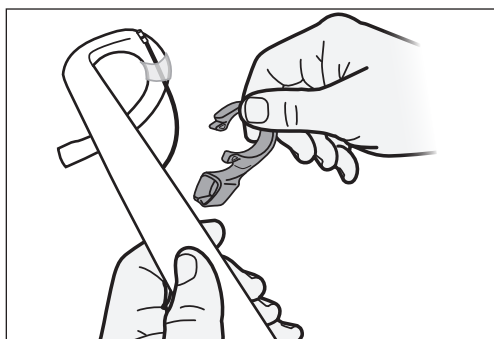

NOTE There are different cabler wranglers for different stems depending on Blendr compatibility. (PNs: 582439, 584649, 587846).

NOTE Trek recommends using the cable wrangler on stems 100mm and longer. For stems shorter than 100mm, the cable wrangler does not provide any additional benefit.

5 Route and install the stem and handlebar

A. Mechanical

Connect the brake hose and housing/cables

Install the top tube cable guide

1. With the cable guide in the correct orientation, snap in the brake hoses first, then the derailleur cables.
 - Drive side: Rear brake hose; rear derailleur cable.
 - Non-drive side: Front brake hose; front derailleur cable.
2. Slide the cable guide down into position in the top of the head tube hole.

NOTE Moto style routing will have the brake hoses swapped.

3. Install the bolt and tighten to 1Nm.

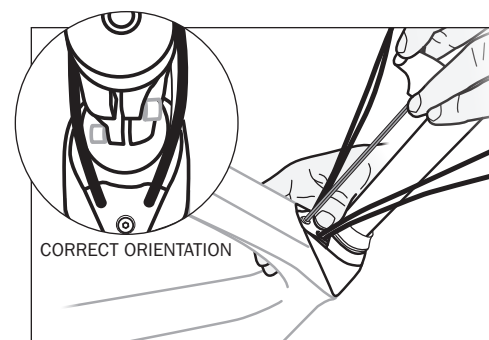

B. Di2

Install the top tube cable guide

1. With the cable guide in the correct orientation, snap in the brake hoses first, then the Di2 wire.
 - Drive side: Rear brake hose; Di2 wire.
 - Non-drive side: Front brake hose.
2. Slide the cable guide down into position in the top of the head tube hole.
3. Install the bolt and tighten to 1Nm.

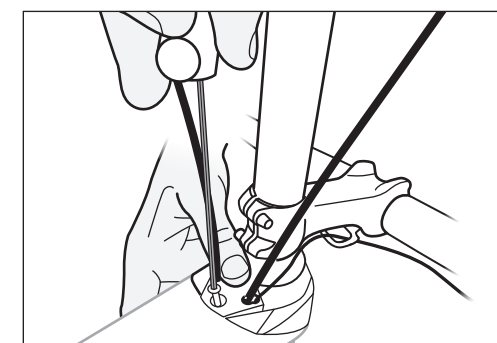

Install the shift levers

1. Route the hoses and wires (Di2) or cables (mechanical) through the cable wrangler.
2. From the wrangler, route the lines along the left and right sides of handlebar.

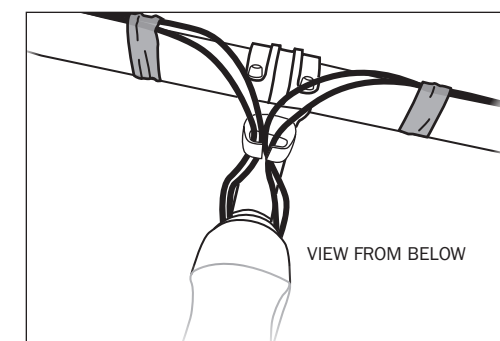

3. Place the shift levers on the handlebar to the desired location.

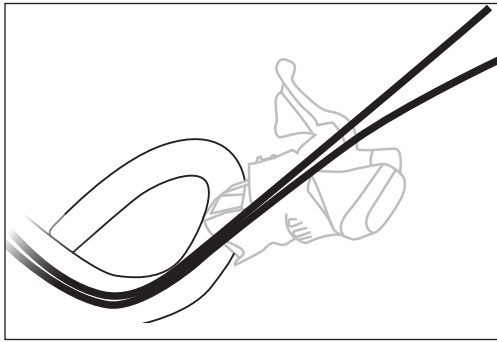

4. Trim the brake hose and shifter housing to the proper length. The cable length should be sufficient to allow the bars to freely rotate +/- 60 degrees.

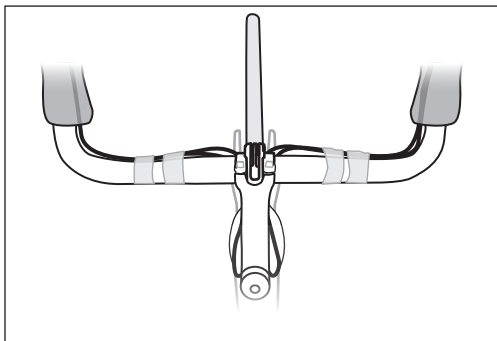
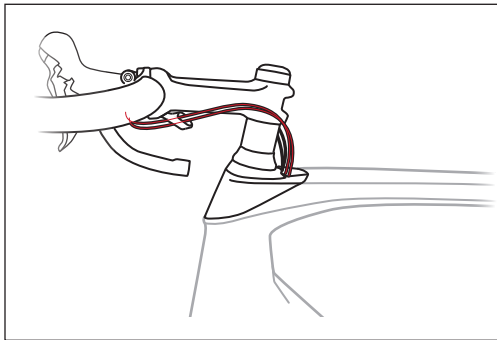

Component	Torque value
Chain keeper bolt	3Nm
Down tube window frame bolt	1.2Nm
Battery holder bolts	0.3Nm
Cable guide to frame bolts	3Nm
Rear Isospeed frame screw	8Nm
Top tube cable guide bolt	1Nm
Damper assembly bolts	5Nm
Bottom bracket	50Nm maximum
Storage door-tool holder screws	1Nm
Seatpost bolt	7Nm

7 SERVICE INFORMATION

Di2 handlebar specifications for reference					
DS shifter to junction A	NDS shifter to junction A	DS shifter to junction B	Battery to junction B	FD to junction B	RD to junction B
300	1200	1400 ¹	300	400	600

NOTE 1 This wire length will change with respect to frame size, stem length, or bar width. All other wire lengths stay the same regardless of frame size.

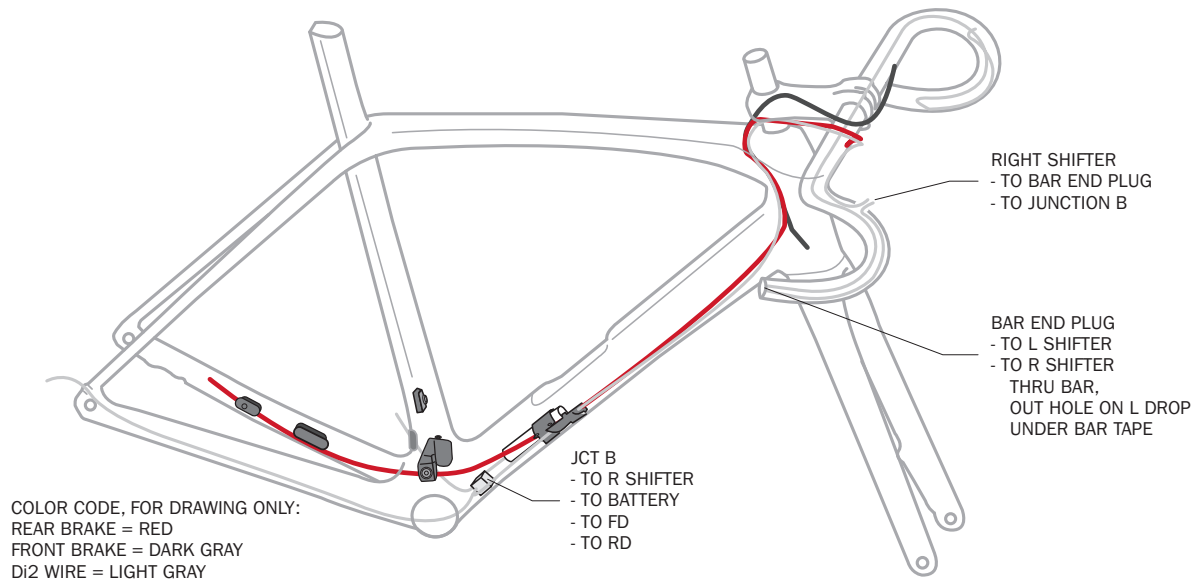

8 APPENDIX

A. Install the front IsoSpeed

1. Apply grease to the bore holes, as well as the inside face and both sides of the head tube.

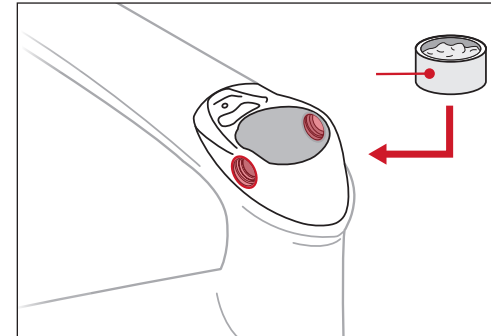

2. Place a washer over each bearing in the front IsoSpeed decoupler.

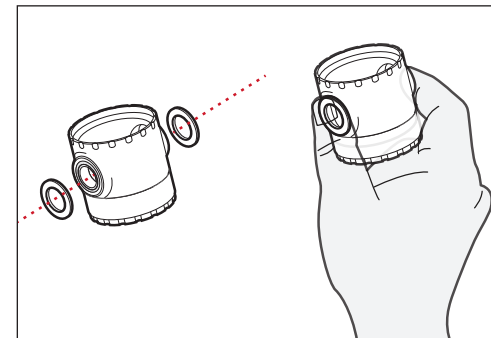

3. Pinch the Front IsoSpeed decoupler between two fingers to hold the washers, and carefully guide it into the cavity in the head tube. Stop when the holes in the decoupler are aligned with the bore holes in the frame.

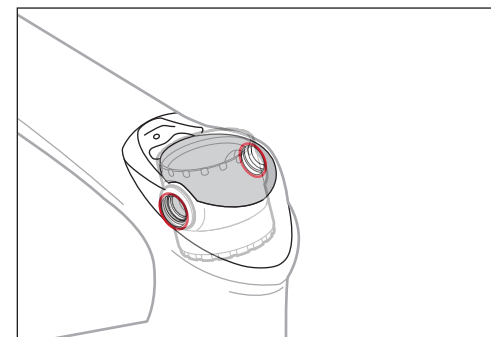

4. From inside the decoupler, insert a screw into the driveside bore hole so the screw points to the outside of the head tube.

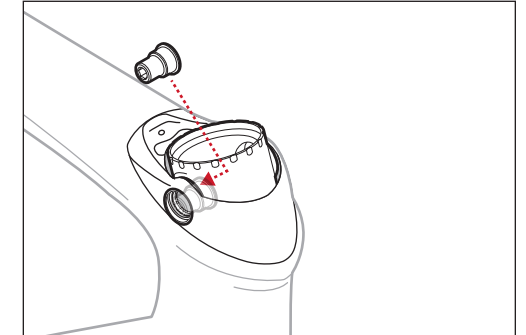

5. Point the end of the elliptical nut with the chamfer towards the bore hole.

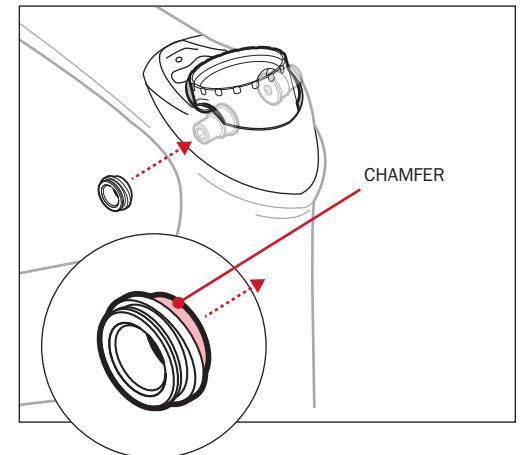

6. Place a finger inside the decoupler and push the screw towards the outside of the head tube.

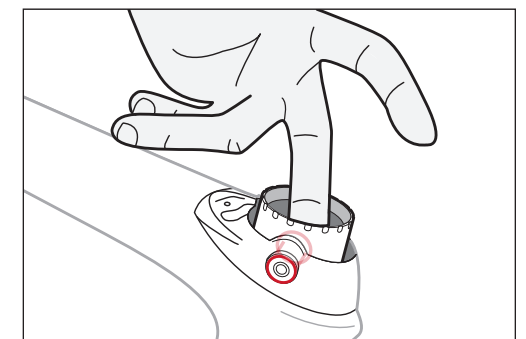

7. Hand thread the elliptical nut a few turns to the LEFT to secure it for the next step. Do not grease the threads.

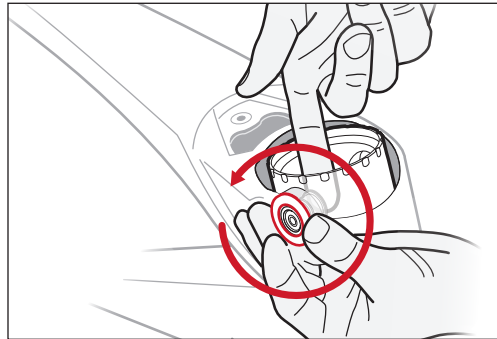

8. The elliptical nut is an oval shape and matches the oval shape of the bore hole in the head tube. When the elliptical nut is hand tight, align the oval of the nut with the style line of the head tube.

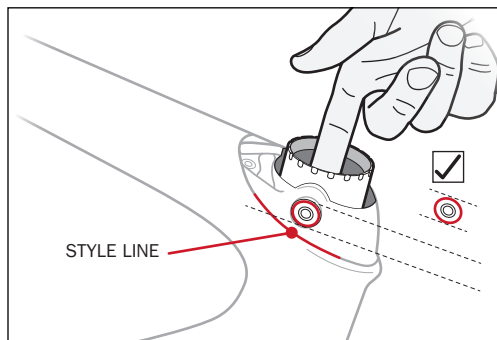

9. Place one hand on the opposite side of the head tube (9a) and with the other, insert the torque key into the nut and apply pressure with both hands until the nut seats into the head tube (9b). Then turn clockwise, with firm pressure (9c). This will draw the screw inside the head tube towards the nut. Turn until snug, do not fully tighten.

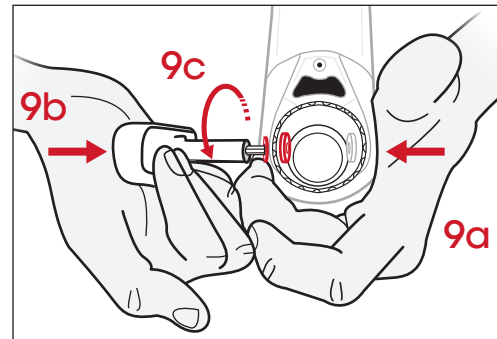

10. Repeat steps 4 through 8 for the other side of the decoupler.

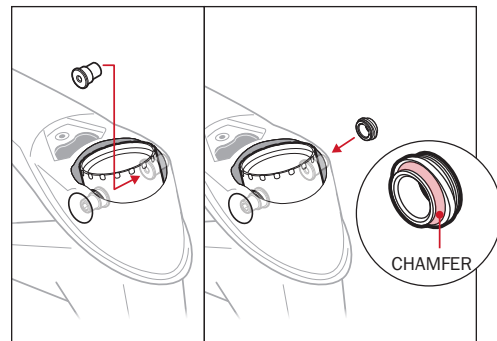

11. Repeat step 9 for the other side.

12. To fully tighten, apply good pressure while turning the torque wrench. This will prevent the bolt inside the decoupler from spinning and will draw it towards the nut. Tighten to a maximum of 8Nm.

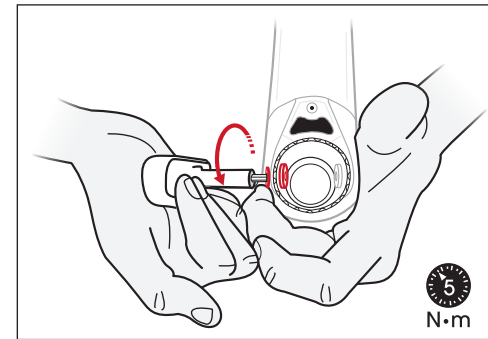

13. Repeat step 12 for the other side.

14. Check the decoupler for free movement after installation. If it does not move freely, loosen, clean the connections, apply grease, and reinstall.

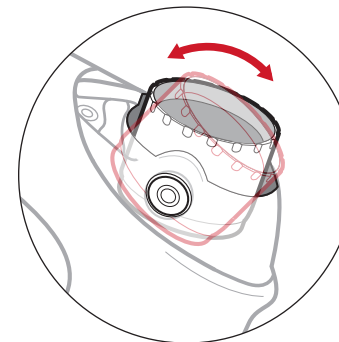

15. Lower the pre-load spacer into the decoupler so that the label "BEARING" is on the top and "SPRING" is pointed down.

NOTE There are flat sides that line up with the screws on either side of the decoupler.

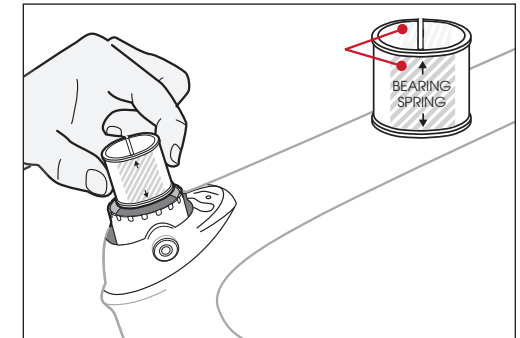

NOTE Grease should not be applied to the IsoSpeed assembly except for the top chamfer where the upper bearing is positioned. Do not apply grease to the lower bearing, wave washer, lower split ring, or spacer.

B. Install the rear IsoSpeed

1. Install the damper assembly in the seat tube. The damper orientation should be up.

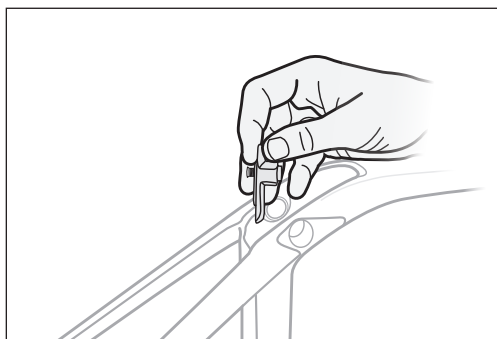

2. Hold the damper assembly in place and install two M4 bolts. Tighten the bolts to 5Nm.



NOTE Make sure the damper adjustment screw is backed out.

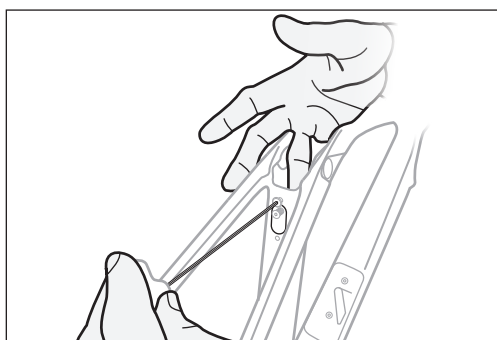

3. Place the IsoSpeed grommet over the top of the seat mast.

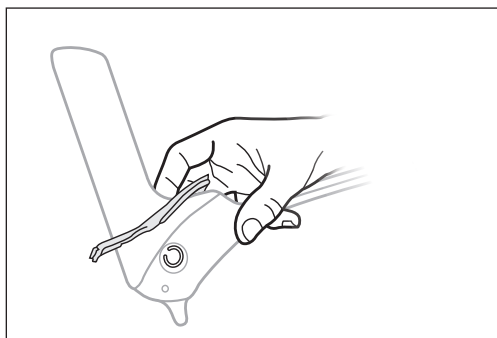

4. Clean the surface with alcohol or similar degreaser and install the adhesive bumper on the forward end of the seat mast tongue.

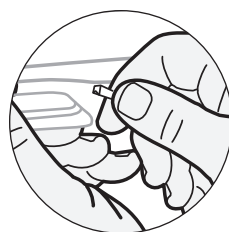

5. Insert the seat mast into the frame.

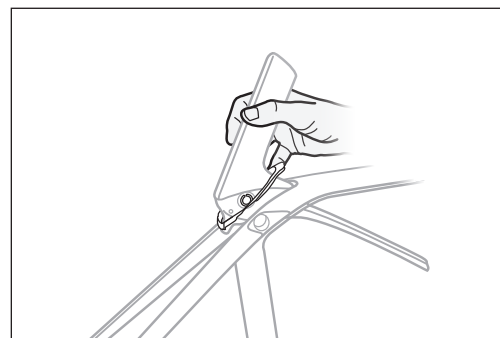

6. Put the grommet in place in the frame.

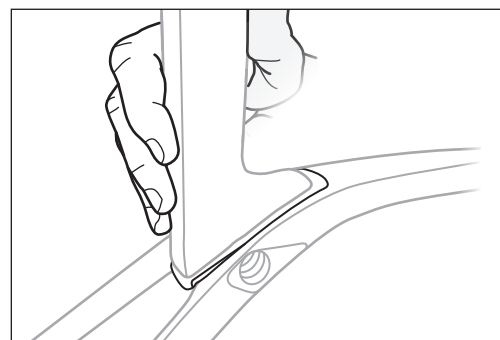

7. Insert the pivot bolt, washer, wave washer, and nut on the non-drive side.

IMPORTANT: The washer and wave washer must be on the bolthead side.

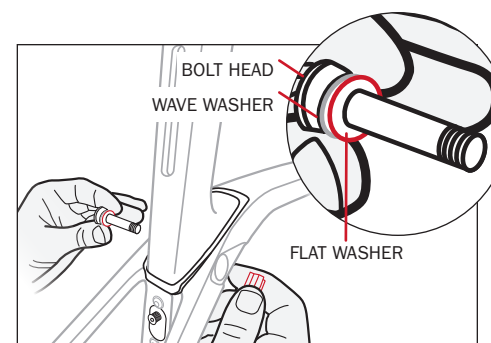

8. Torque the bolt to 8Nm. Use the torque wrench on the 8mm side, not the 6mm side.

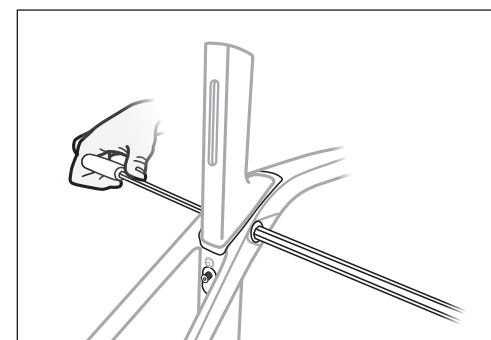

9. Install the slider on the seat mast tongue.

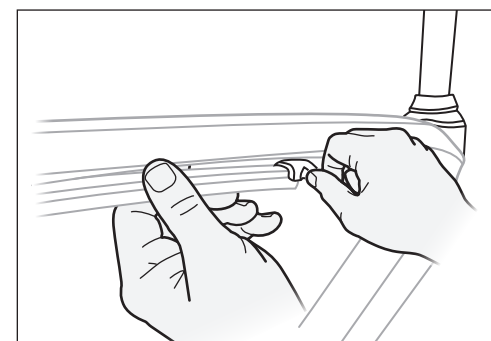

10. Install the bolt and washer in the forward end of the decoupler and torque to spec on decal.

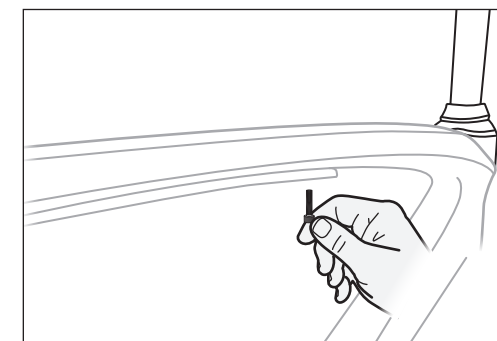

11. Tighten the damper adjustment screw.

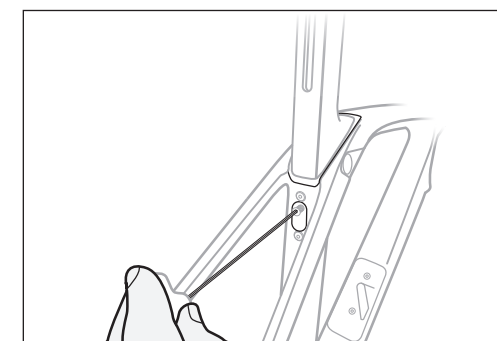

C. Assemble and install the DT storage door

PARTS REQUIRED:

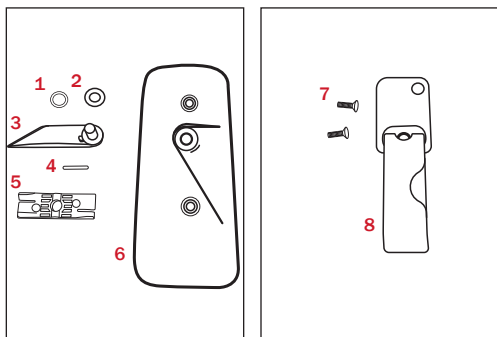

- | | |
|----------------|---------------------------|
| 1. Wave washer | 5. Wings |
| 2. Flat washer | 6. Storage door |
| 3. Lever | 7. Screws (2) |
| 4. Pin | 8. Wing cover/Tool holder |

- 1.** Preload the pin in the wing.



NOTE

Make sure the pin is not pressed into the hole in the middle of the wings.

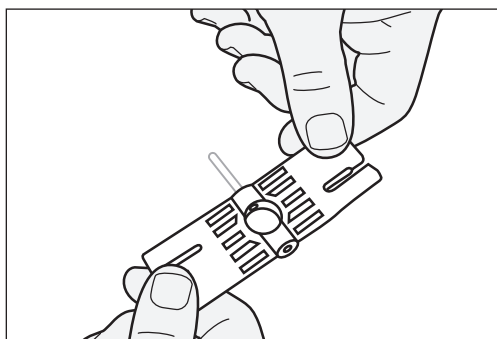

- 2.** Put the straight washer on the lever shaft.

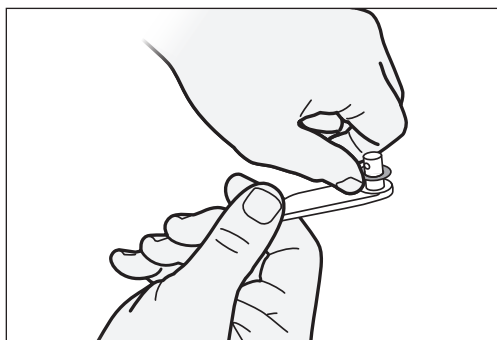

- 3.** From the inside, put the wave spring over the lever shaft.

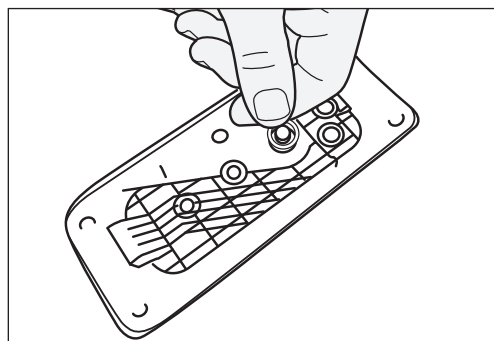

- 4.** Put the wing over the lever shaft with the wing ribbing visible.

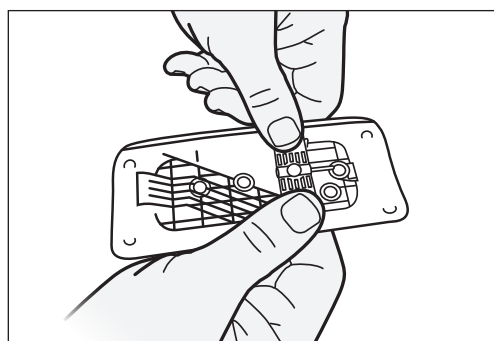

- 5.** Line up the holes in the shaft and the wing with the lever in the closed position and the wing perpendicular to the water bottle line.

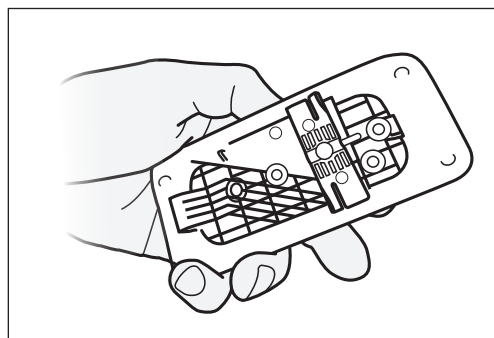

- 6.** Press the pin through so it's flush with the wing.

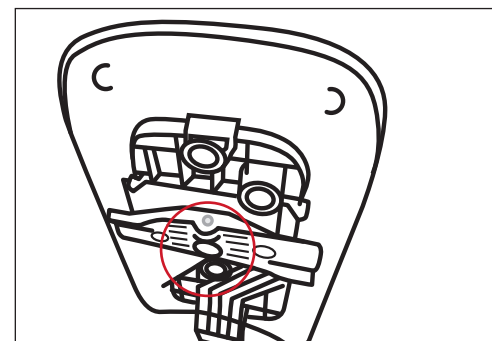

- 7.** Set the tool holder tab in the channel on the door.

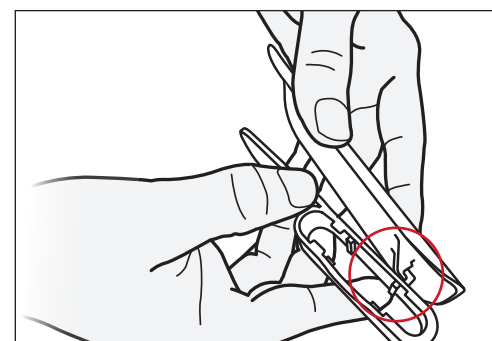

- 8.** Install and torque the two screws to 1Nm.

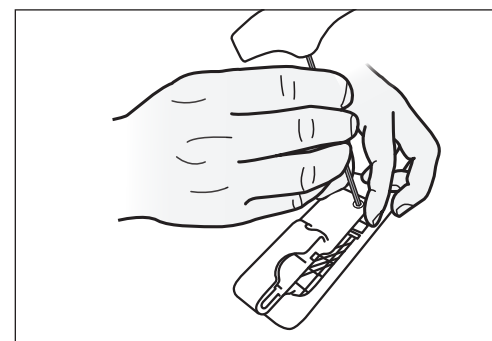

- 9.** If equipped with a Bontrager multi-tool, push the tool into the holder from the non-notched side until it clicks into place.

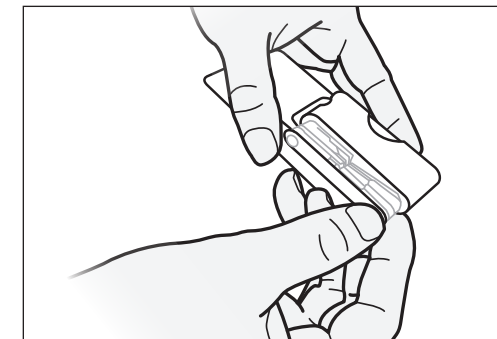

- 10.** To release the tool, push on the tool at the notch and pull up on the opposite side of the holder. Push the tool out at an approximate 45-degree angle.

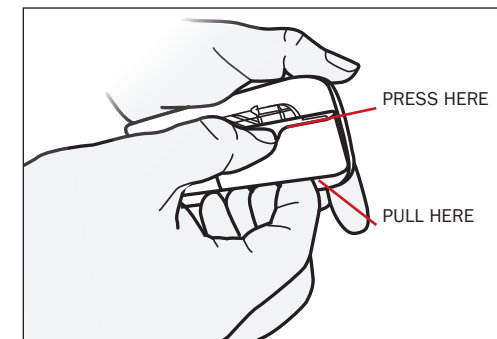

D. Install the T47 bottom bracket

1. Grease the threads on the bottom bracket.

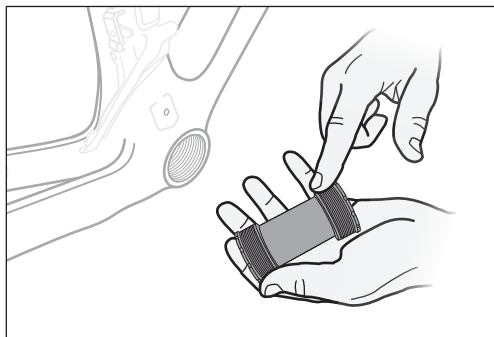

2. Grease the threads on the frame

3. Start threading the bottom bracket into the frame by hand:
 - Drive side: reverse threads (left hand thread)
 - Non-drive side: regular threads (right hand threads)

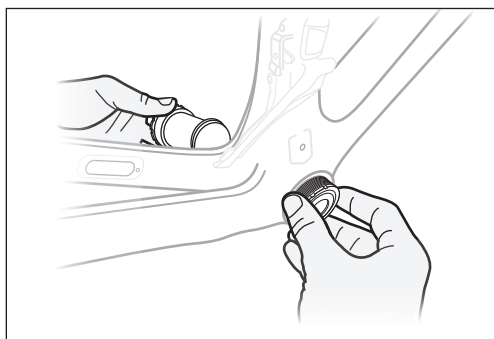

4. Use the installation tool specific to your bottom bracket to torque the bracket to the OEM spec. Do not exceed a maximum of 50Nm.

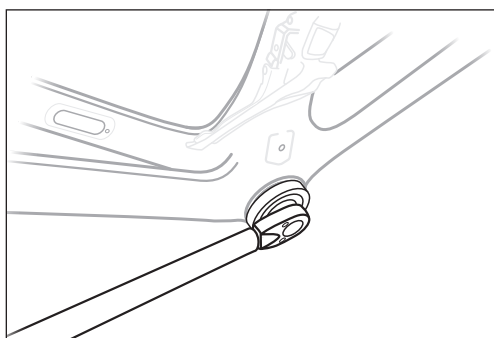

E. Install front fender

TOOLS REQUIRED

- 4mm hex head wrench, extended arm, round head
- Loctite Blue 242

Trek recommends using Bontrager fenders.

Domane SL, SLR, and LT models

1. Remove the set screw or plastic plug from under the fork crown.
2. Remove the two bolts from the fender mounting tab and remove the tab.

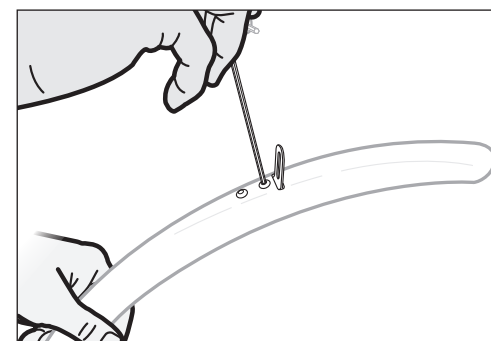

3. If the top mounting bolt has been used before or the bolt has no adhesive, apply fresh Loctite Blue 242 to coat the threads.

NOTE The bolts included with your Bontrager fender will have Loctite pre-applied. The top mounting bolt should be a button-head type and at least 0.5in (12.7mm) long.

4. Use the bolt with Loctite to attach the fender to the underside of the fork crown.

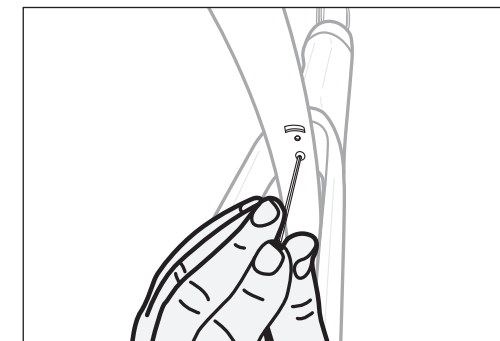

5. Use the instructions that came with the fender to complete the installation.

Domane HP models

1. Remove the set screw or plastic plug from the rear of the fork.
2. If the top mounting bolt has been used before or the bolt has no adhesive, apply fresh Loctite Blue 242 to coat the threads.

NOTE The bolts included with your Bontrager fender will have Loctite pre-applied.

3. Bend the fender tab as necessary to best fit the angle of the fork.
4. Use the bolt with Loctite to attach the fender to the rear of the fork.

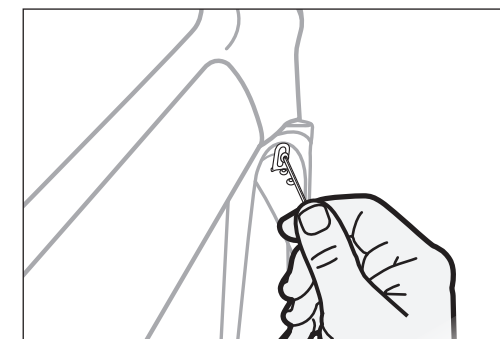

5. Use the instructions that came with the fender to complete the installation.

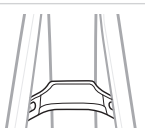
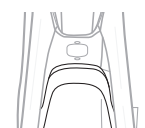
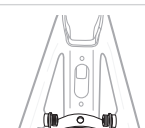
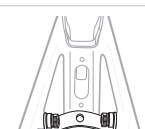
Rear fender chart					
Part Number	Description	Frame Size			
		Domane SL	Domane SLR	Domane+ LT	Domane+ HP
575637	 Center mount facing down	56 – 62	56 – 62	56 – 62	
575637	 Center mount facing up	47 – 54	52 – 54	52 – 54	
595608	 Fender mount - small	44	47 – 50	50	
592674	 Spacers or struts installed outside of fender bridge/inside of seat stay.				56 – 60
592674	 Spacers or struts installed inside of fender bridge/under bolt head.				52 – 54



